

Fiorentini Series C IM-RM Rotary Meter

Installation Instruction

This manual is only intended to trained and experienced personnel for the supply, distribution and measurement of energy and gas, and have sufficient technical knowledge and experience.

The meters rotor C-IM-RM series are suitable for non-aggressive gases, clean and dry:

Natural gas, argon, butane, ethane, nitrogen oxide and carbon dioxide, air, methane, pentane, propane.

For other applications please contact Fiorentini

Environmental conditions: mechanical class M1 Electromagnetic class E1.

The permissible ambient temperature range is printed on the nameplate.

The counter can be placed outdoors, but be careful not to expose it to direct sunlight.

IP protection class: IP67.

OPERATIONS AND CHECKS TO PERFORM:





- 1) Check the meter for damage due to transportation and handling. The rotors should rotate freely.
- 2) Check the flow direction, as indicated on the type plate. In case the flow direction is incorrect, the meter must be replaced by one with correct flow direction.
The C series meters are available in three flow configurations:
 - **Single Position:** Left > Right & High > Low
 - **Single position:** right > left & Low > High
 - **Multiposition:** All flow directions are possible. This configuration provides the pressure taps and the temperature measuring points on both sides of the meter. These accessories can be supplied already mounted in the correct locations, or provided separately.
- For **Pm** and **T** tapping see figures on pages 3-6.
- 3) The installation must be free of dirt, welding beads and water in the pipes. The piping on the inlet side of the meter must be clean. It is recommended to install a 100 micron filter upstream of the meter. For new installations, it is recommended to install a wire mesh filter (250 micron) for first weeks of operation.
- 4) The meter must be installed free of piping strain. Level the meter to within 5mm/m side-to-side and front-to-back
- 5) The maximum torque on the bolts for aluminum flanges is BSP G1½ 100 Nm, M16 (5/8"UNC) 130 Nm, M20 (3/4"UNC) 180 Nm, fasten the bolts crosswise.
- 6) The index can be rotated for about 350 degrees. To change from horizontal to vertical rotate the index 270 degrees clock wise.
- 7) The meter is shipped without oil in the reservoir. Fill the meter at the front side to the indicated level with the oil supplied (see figures on pages 3-6). For a correct reading of the oil level it will take a few minutes for stabilizing.
- 8) Pressurize the meter with care to avoid overloading. **Do not exceed 5 psig/second** (35 kPa/sec. - 0.35 bar/sec) **maximum when pressurizing.**
- 9) Connect the electrical pulses in accordance with the connection diagrams at page 7. The connector is in conformity with IP67 if all the plugs are connected.
- 10) Check the meter to determine there is no vibration. An indication of the meter condition can be obtained by analyzing the pressure drop over the meter (**Pm** point vs. **p** point). It is recommended to record the pressure drop over the new meter at different flow rates. This value can be compared to future measurement.

Precautions:

- Never use the meter as a distance piece during welding.
- The meter must be out of service and depressurized before filling or adding oil.
- Before removing the meter the oil should be drained.
- The meter should be transported and stored with the rotor axis in a horizontal position.
- The maximum torque on the **p** and **Pm** connection is: 30 Nm.
- To tighten the coupling. Use 2 wrenches to avoid rotation of the **p** and **Pm** connection thread in the body.

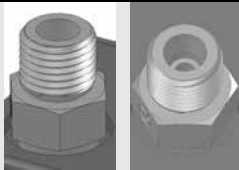
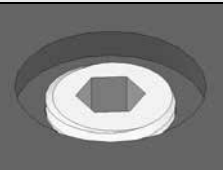
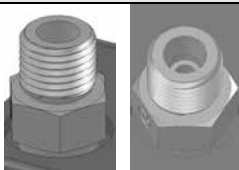
Plugs

The below table describe the connection used

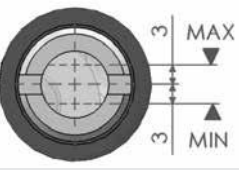
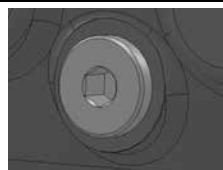
<p>Pm</p>	<p>Pressure reference point to be connected to a volume conversion device. In previous time this was also known as Pr.</p>	 <p>Plug 1/4" NPT, Allen key 1/4" AF</p>	<p>or</p>  <p>Ermeto-Original - EO6</p>
<p>P</p>	<p>Pressure point</p>	 <p>Plug 1/4" NPT, Allen key 1/4" AF</p>	<p>or</p>  <p>Ermeto-Original - EO6</p>
<p>T</p>	<p>Temperature measure point. Thermowell with internal size 7mm Equipped with a cable gland M12 to fix the cable.</p>	 <p>Plug 1/4" NPT, Allen key 1/4" AF</p>	<p>or</p>  <p>Thermowell Di= 7mm,</p>
<p>F</p>	<p>Oil filling plug</p>	 <p>Plug 9/16"-18 UNF, Allen key 1/4" AF</p>	
<p>S</p>	<p>Oil sight glass. Use only oil for Fiorentini Meters. 1ml=1cc=0.034 U.S. o.z.</p>	 <p>Plug 9/16" - 18 UNF</p>	
<p>D</p>	<p>Oil drain plug</p>	 <p>Plug 9/16", Allen key 1/4" AF</p>	

L= 121 mm BSP G1½ threaded connection

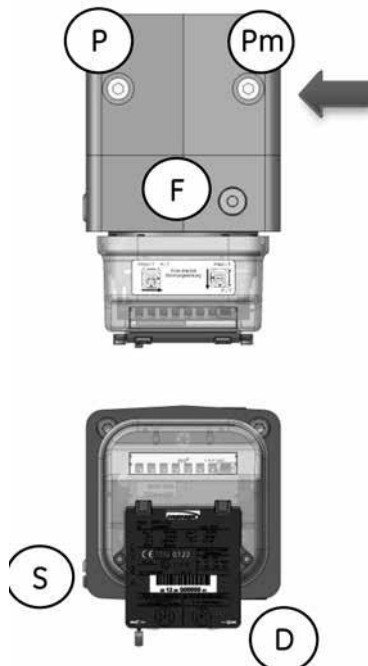
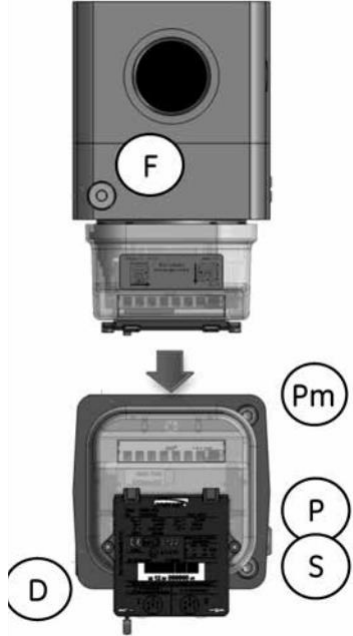
STD: Left > Right	Right > Left *	Top > Bottom (Bottom > Top)
		
1 x oil 15 ml	1 x oil 15 ml	1 x oil 35 ml

Flow direction indicated on index. BSP G1½ x 20mm max. Torque Max 100 Nm

* The meter with flow Right > Left can also be used with direction Bottom > Top

L= 171 mm Flanged Connections PN16 or ANSI150

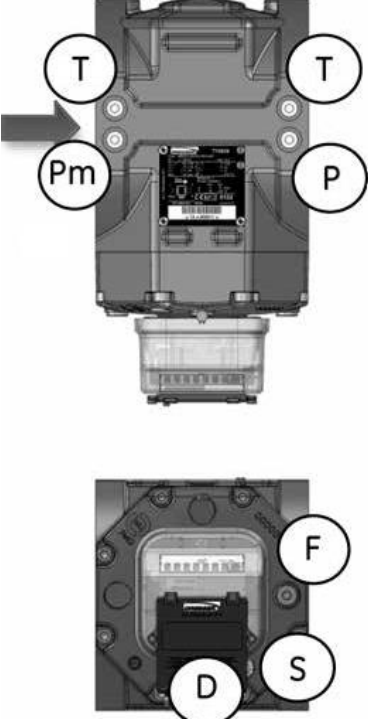
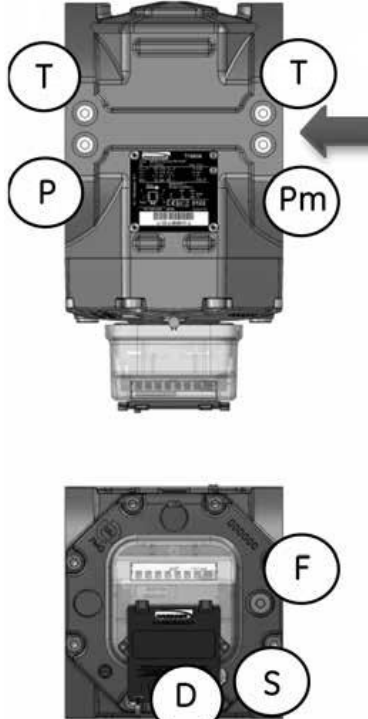
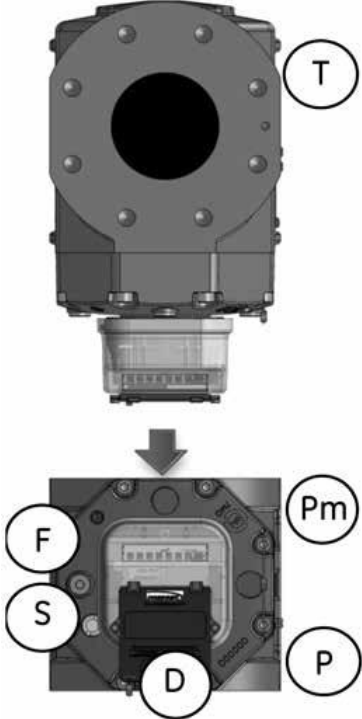
		
1 x oil 25 ml	1 x oil 25 ml	1 x oil 120 ml

Flow direction indicated on index or on the label.

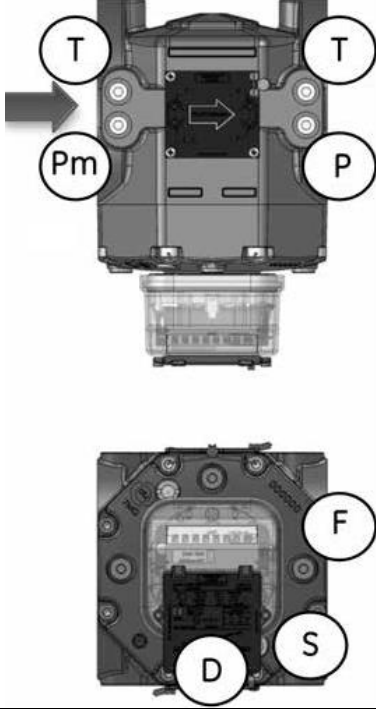
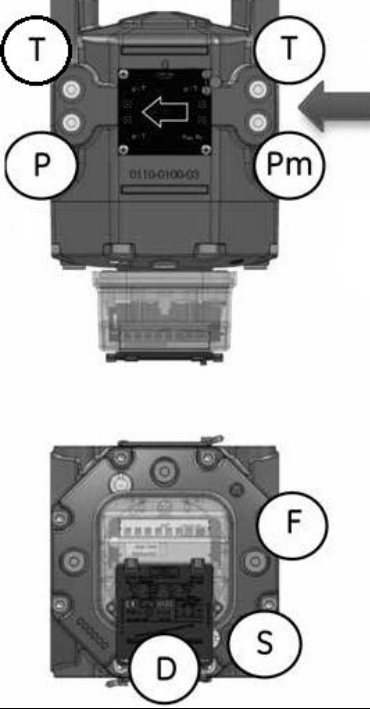
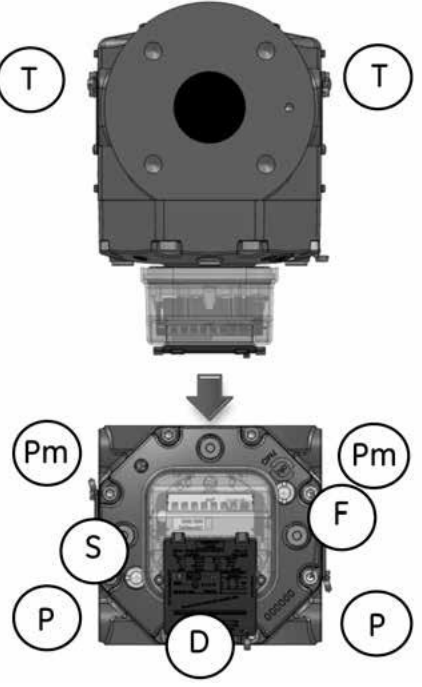

* The meter with flow Right > Left can also be used with direction Bottom > Top

MULTIPOSITION L= 171 mm Flanged Connections PN16 or ANSI150

STD: Left > Right	Right > Left *	Top > Bottom (Bottom > Top)
		
1 x oil 25 ml	1 x oil 25 ml	1 x oil 120 ml

Flow direction indicated on the label placed on the meter body.
 The MULTIPosition configuration provides the pressure and temperature measuring points on both sides of the meter.
 All flow directions are possible.

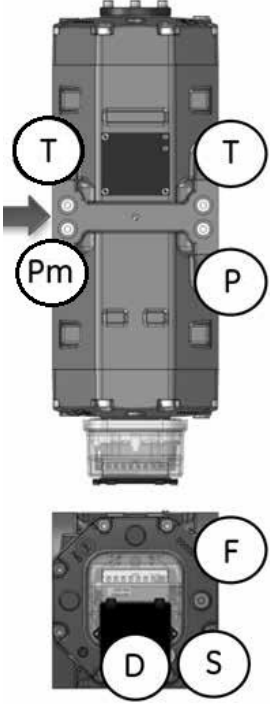
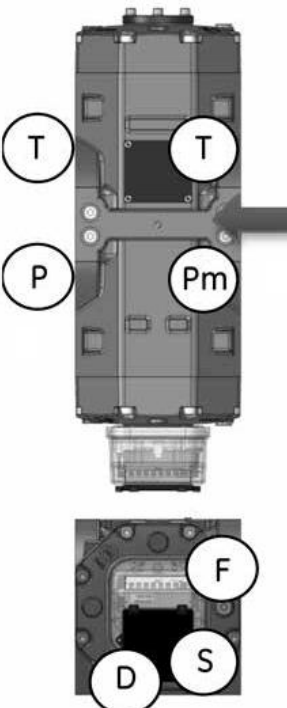
L= 171 mm Twin Flanged Connections PN16 or ANSI150

		
2 x oil 25 ml	2 x oil 25 ml	2 x oil 120 ml

Flow direction indicated on index or on the label.
 * The meter with flow Right > Left can also be used with direction Bottom > Top

L= 241 mm Flanged Connections PN16 or ANSI150

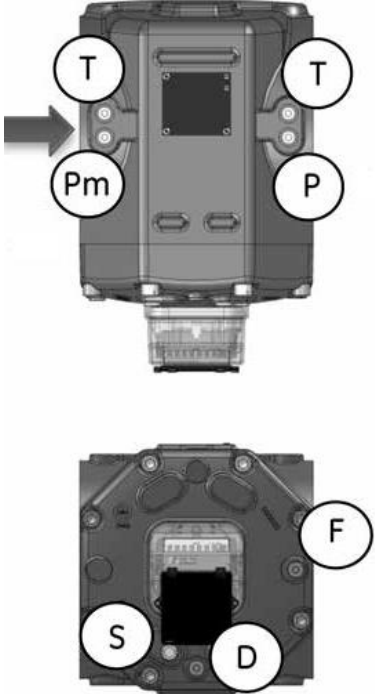
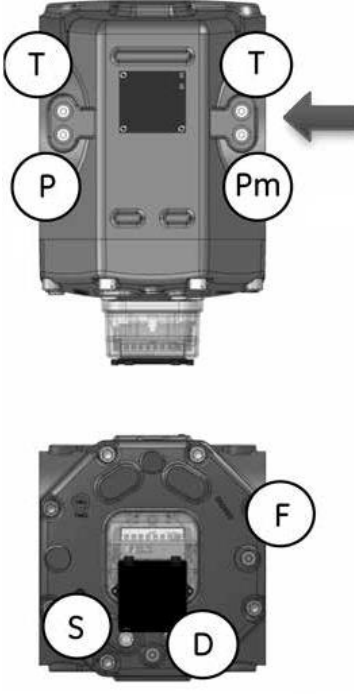
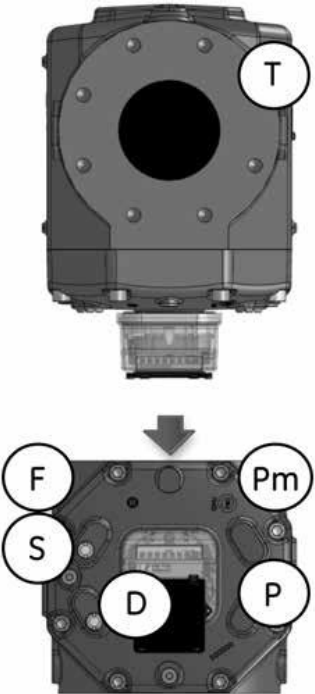
STD: Left > Right	Right > Left *	Top > Bottom (Bottom > Top)
		
1 x oil 60 ml	1 x oil 60 ml	1 x oil 345 ml

Flow direction indicated on index or on the label.

* The meter with flow Right > Left can also be used with direction Bottom > Top

MULTIPOSITION L= 241 mm Flanged Connections PN16 or ANSI150

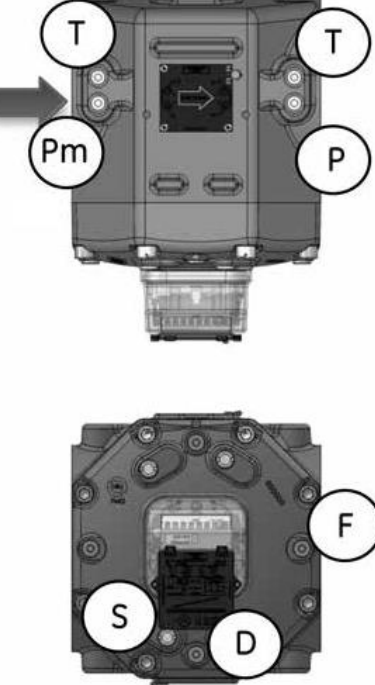
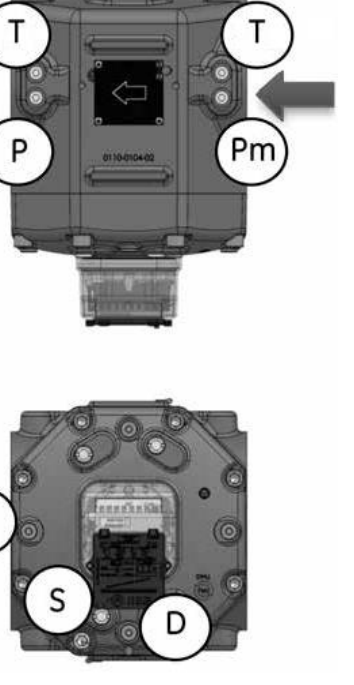
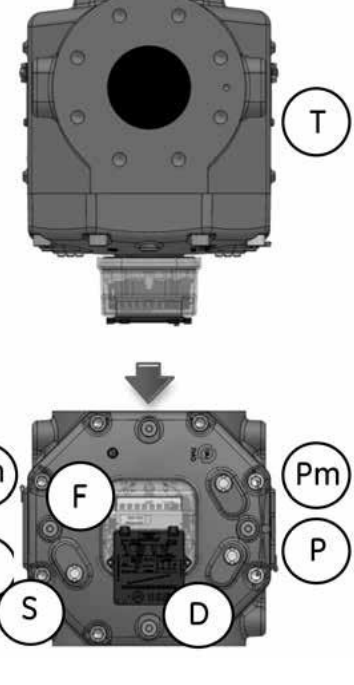
		
1 x oil 60 ml	1 x oil 60 ml	1 x oil 345 ml

Flow direction indicated on the label placed on the meter body.

The MULTIPosition configuration provides the outlets of pressure and temperature measuring points on both sides of the meter. All flow directions are possible.

L= 241 mm Twin Flanged Connections PN16 or ANSI150

STD: Left > Right	Right > Left *	Top > Bottom (Bottom > Top)
2 x oil 60 ml	2 x oil 60 ml	2 x oil 345 ml
Flow direction indicated on index or on the label. * The meter with flow Right > Left can also be used with direction Bottom > Top		

LENGTH OF THREAD

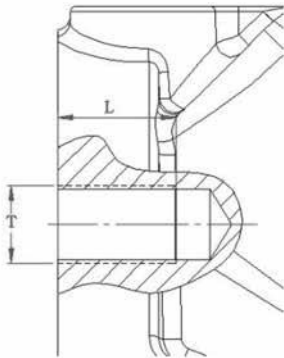

T = Thread diameter
 L = Length of Thread (mm)

	Threaded	Flanged									
	BSPP G1-1/2"	DN 1-1/2"		DN 2"		DN 3"		DN 4"		DN 6	
	-	ANSI	DIN	ANSI	DIN	ANSI	DIN	ANSI	DIN	ANSI	DIN
T	BSPP G1-1/2"	1/2UNC	M16	5/8UNC	M16	5/8UNC	M16	5/8UNC	M16	3/4UNC	M20
L	20	19	24	24	24	24	24	24	24	29	30

ELECTRIC CONNECTION



Electric connection only to be connected to an **intrinsic safe** electrical circuit. Only qualified staff with a knowledge of protection classes, regulations and provisions for apparatus in hazardous locations may install, connect and set up the units. Check whether the classification is suitable for the application.

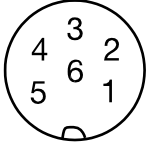

Low Frequency sensor index

Pin configuration from the pulse box located on the index

1 - 4	1 tr. = 1 imp.
2 - 5	1 tr. = 1 imp.
3 - 6	N.C. Reed Switch

For more details ask for iTN 33101

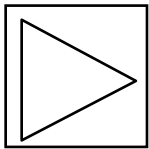

Sensor connection:

Only to intrinsically safe certified circuits or evaluation amplifiers which do not exceed the following maximum values of the units:

$U_i = 15 \text{ V}$, $I_i = 50 \text{ mA}$, $P_i = 120 \text{ mW}$

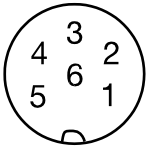

High frequency sensor

Pin configuration

3(-) 6(+) pulse output 1

For more details ask for iTN 33102.

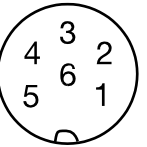

Encoder Pin Configuration

Pin configuration

1 (+)	2 (-)	data output
3 (+)	6 (-)	pulse output 1
4 (-)	5 (+)	pulse output 2

High frequency sensors

When powered this 2 wire high frequency sensor change its current. The switching amplifier limits voltage and its current according the NAMUR protocol EN 60947-5-6 and avoids damage to the sensor that could result in the ignition of gas. For amplifiers contact Fiorentini sales.

Installation remarks/Mounting

1. Adhere to the relevant national regulations and provisions.
2. Avoid electrostatic charging from housings and cables.
3. Sockets must be protected against intensive electrostatic charging.
4. To avoid electrostatic charging steps must be taken to ensure the equalization of potential of metal parts (plug housing, fixing elements, etc.)



Should after reading this manual carefully any doubts or questions remain, contact your Fiorentini representative before any actions taken.

Cable

If a cable is supplied, the color codes are:

1	White
2	Brown
3	Green
4	Yellow
5	Grey
6	Pink



www.fiorentini.com

TDO60509-EN-Rev6 10/18